



**Model No. RML-635R-XFYP2Q**  
**635nm RED DIODE LASER SYSTEM UP TO >150mW**

The RML-series 635 nm red diode laser is constructed with features of high stability, FDA compliance, circular beam, ultra-compactness, long lifetime, cost-effectiveness and easy operating. It is widely used in measurement, spectrum analysis, laser lighting show, and many other applications. *In addition, fiber coupled RML-series 635nm diode lasers with FC or SMA905 connector are available upon request.*

**SPECIFICATIONS**

<b>Model No.</b>	<b>RML-635R-XFYP2Q</b>
<b>Wavelength (nm)</b>	635±10
<b>Output power (mW)</b>	>50 (X=50), >100 (X=100), >150 (X=150)
<b>Transverse mode</b>	Round
<b>Operating mode</b>	CW
<b>Power stability (rms, over 4 hours)</b>	<1% (P=D)
<b>Beam diameter at aperture (1/e<sup>2</sup>, mm)</b>	~2
<b>Beam divergence, full angle (mrad)</b>	<18
<b>Warm-up time (minutes)</b>	<5
<b>Beam height from base plate (mm)</b>	24.8
<b>Operating temperature (°C)</b>	10~35
<b>Laser head</b>	143.5(L) x73(W) x46.2(H) mm <sup>3</sup> , 0.7 kg
<b>Power supply (90-240VAC)</b>	<b>Elite Power Supply (Y=E):</b> 171(L) x130(W) x62.2(H) mm <sup>3</sup> , 1.2kg; complete FDA compliant features (turnkey switch and interlock); easy to operate; CW mode with optional TTL or Analog modulation up to 30kHz  <b>Laboratory Power Supply (Y=L):</b> 188.6(L) x155(W) x92(H) mm <sup>3</sup> , 1.5kg; complete FDA compliant features (turnkey switch and interlock) with more functions; CW mode with adjustable output power knob, operating current LED display, and optional TTL or Analog modulation up to 30kHz
<b>Optional modulation</b>	None (Q=0) TTL: 1Hz -1kHz (Q=1), 1kHz -10kHz (Q=2), 10kHz-30kHz (Q=5) Analog: 1Hz -1kHz (Q=3), 1kHz -10kHz (Q=4), 10kHz-30kHz (Q=6)
<b>Expected lifetime (hours)</b>	10,000
<b>Warranty</b>	10 months
<b>Remarks</b>	The stability of output power may change when you adjust the output power. For example, the stability of output power at the maximum output power is <10%, the stability may change to >10% when you adjust the output power down.

**Note: The above specifications are subject to change without notice.**





**MECHANICAL OUTLINE (unit: mm)**

**Laser Head**

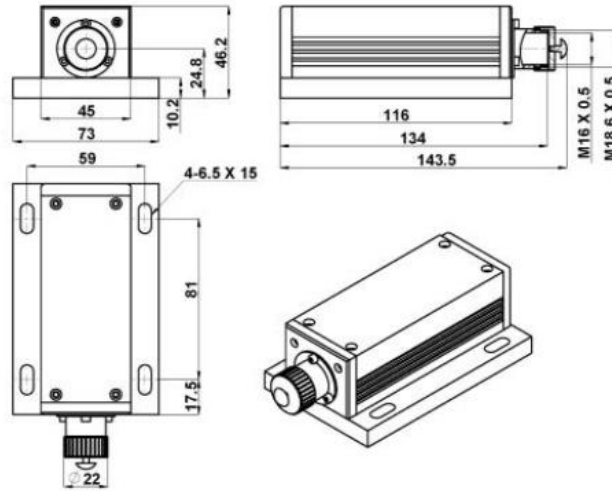

**Power Supply**

**Elite Power Supply (Y=E)**

**Laboratory Power Supply (Y=L)**

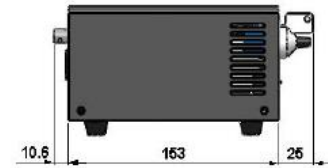
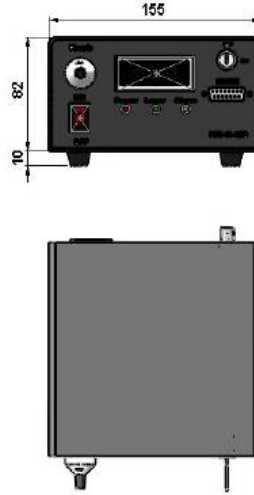
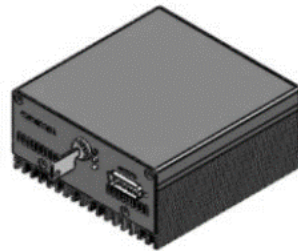
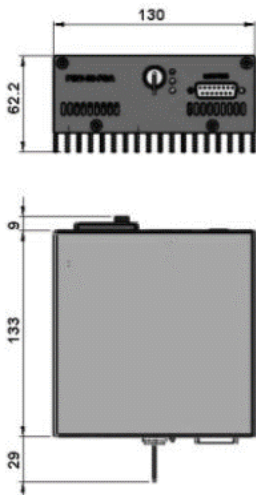

**Note: The above specifications are subject to change without notice.**