



Model No. IML-808H-XFYPZQ
808nm INFRARED DIODE LASER SYSTEM UP TO >100mW

The IML-series 808 nm infrared diode laser is constructed with features of high stability, low noise option, FDA compliance, ultra-compactness, long lifetime, cost-effectiveness, better beam quality with TEM₀₀ and easy operating. It is widely used in measurement, spectrum analysis, communication, and many other applications. *In addition, fiber coupled IML-series 808nm diode lasers with FC or SMA905 connector are available upon request.*

SPECIFICATIONS

Model No.	IML-808H-XFYPZQ
Wavelength (nm)	808±3
Output power (mW)	>50 (X=50), >100 (X=100)
Transverse mode	Near TEM ₀₀
Operating mode	CW
Power stability (rms, over 4 hours)	<0.5% (P=S), <1% (P=D)
Noise of amplitude (rms, 20Hz~20MHz)	<1% for Low Noise (Z=1); >1% (Z=2)
Dimensions of beam at aperture (1/e², mm)	~3.5
Beam divergence, full angle (mrad)	<1.0
Polarization ratio	>50:1, Horizontal ±5 degree
Warm-up time (minutes)	<5
Pointing stability after warm-up (mrad)	<0.05
Beam height from base plate (mm)	24.8
Operating temperature (°C)	10~35
Laser head	143.5(L) x73(W) x46.2(H) mm ³ , 0.7 kg
Power supply (90-240VAC)	Elite Power Supply (Y=E): 171(L) x130(W) x62.2(H) mm ³ , 1.2kg; complete FDA compliant features (turnkey switch and interlock); easy to operate; CW mode with optional TTL or Analog modulation up to 30kHz Laboratory Power Supply (Y=L): 188.6(L) x155(W) x92(H) mm ³ , 1.5kg; complete FDA compliant features (turnkey switch and interlock) with more functions; CW mode with adjustable output power knob, operating current LED display, and optional TTL or Analog modulation up to 30kHz
Optional modulation	None (Q=0) TTL: 1Hz -1kHz (Q=1), 1kHz -10kHz (Q=2), 10kHz-30kHz (Q=5) Analog: 1Hz -1kHz (Q=3), 1kHz -10kHz (Q=4), 10kHz-30kHz (Q=6)
Expected lifetime (hours)	10,000
Warranty	10 months
Remarks	The stability of output power may change when you adjust the output power. For example, the stability of output power at the maximum output power is <10%, the stability may change to >10% when you adjust the output power down.

Note: The above specifications are subject to change without notice.





MECHANICAL OUTLINE (unit: mm)

Laser Head

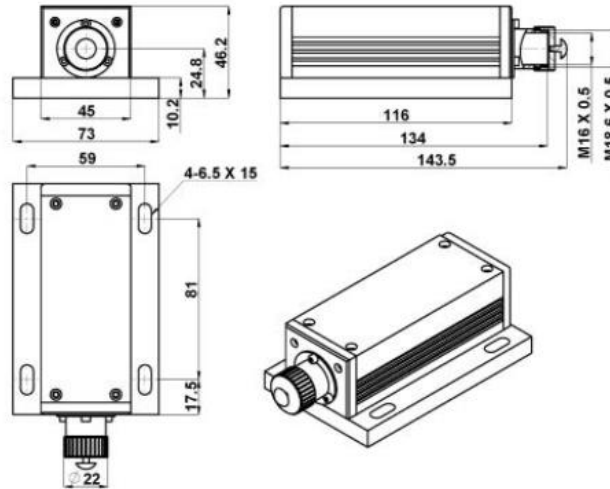

Power Supply

Elite Power Supply (Y=E)

Laboratory Power Supply (Y=L)

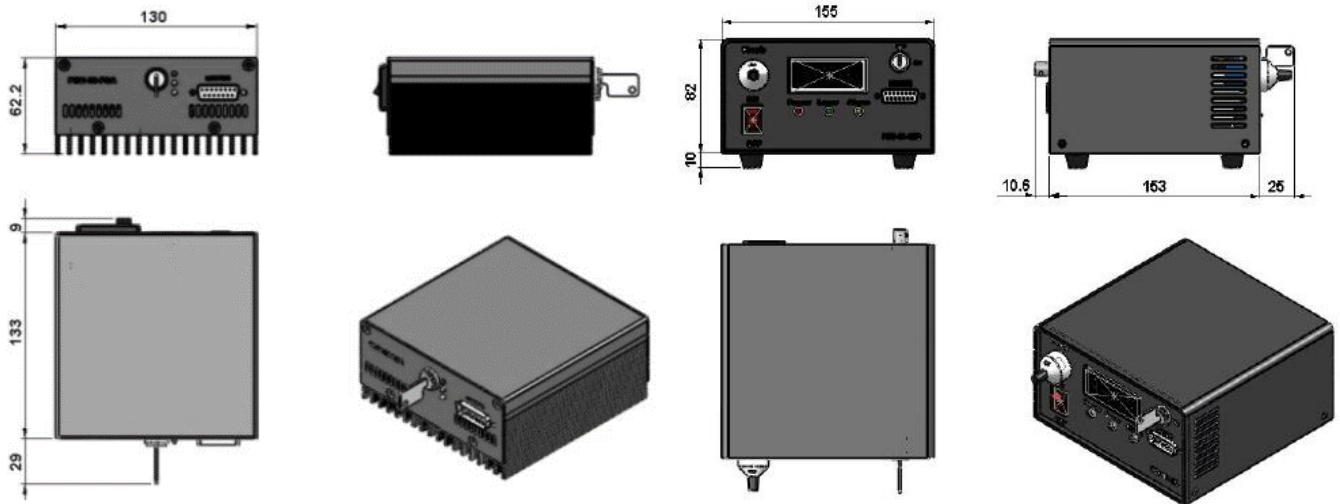

Note: The above specifications are subject to change without notice.